

R/A COAX PLUG + HOUSING

R197.120.B01

CABLE 5/50

Series : SMB
CARLOCK

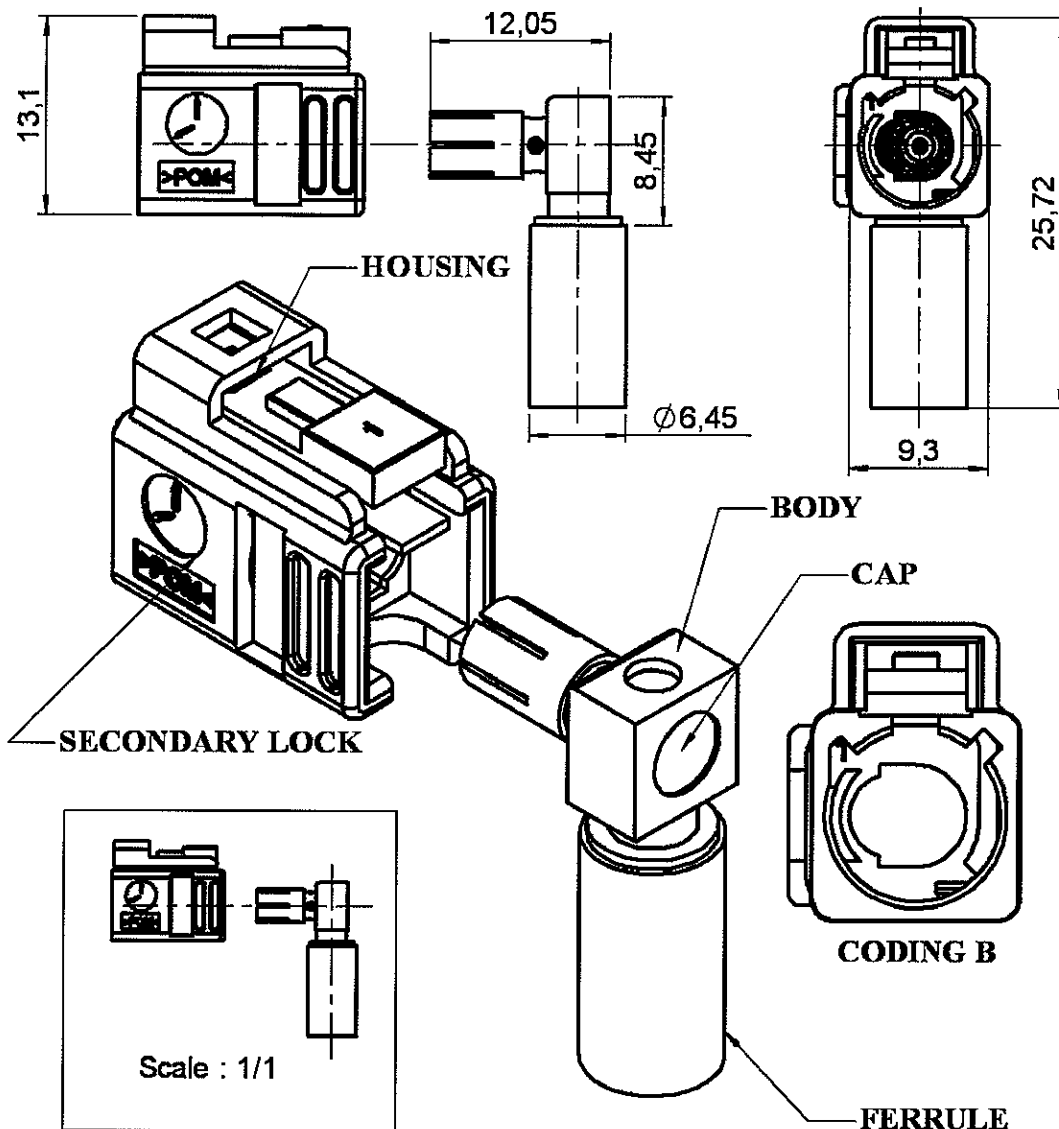

All dimensions are in mm.

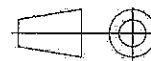

COMPONENTS	MATERIALS	PLATINGS (µm)
BODY	BRASS	NICKEL 2
CENTER CONTACT	BRONZE	GOLD 0.8 OVER NICKEL 2
OUTER CONTACT	BRONZE	NICKEL 2
INSULATOR	PTFE	
GASKET		
OTHERS PARTS	BRASS	NICKEL 2
HOUSING	Polyoxyméthylène (POM)	UL CLASSIFICATION
Secondary Lock	Polyoxyméthylène (POM)	UL 94V-2
		COLOR
		WHITE RAL9003
		PURPLE RAL4003

*According with FAKRA specifications

Issue : 0115 B

In the effort to improve our products, we reserve the right to make changes judged to be necessary.



R/A COAX PLUG + HOUSING

R197.120.B01

CABLE 5/50

Series : SMB
CARLOCK

PACKAGING

SPECIFICATION

QS9000

Standard	Unit	Other
100	'W' option	Contact us

CABLE ASSEMBLY

ELECTRICAL CHARACTERISTICS

Impedance		50 Ω
Frequency range		0-2 GHz
VSWR	1.03 + 0.050	x F(GHz) Maxi
Insertion loss		0.25 √F(GHz) dB Maxi
RF leakage	- (- F(GHz)) dB Maxi
Voltage rating		335 Veff Maxi
Dielectric withstanding voltage		1000 Veff mini
Insulation resistance		1000 MΩ mini

Stripping	a	b	c	d	e	f
mm	5.00	8.00	15.0	10.0	0.00	0.00

Assembly instruction : **page 3**

Recommended cable(s)
RG 58

Cable retention
- pull off **180** N mini
- torque N.cm

MECHANICAL CHARACTERISTICS

Center contact retention		
Axial force -- Mating end	10	N mini
Axial force - Opposite end	10	N mini
Torque		N.cm mini

Recommended torque		
Mating		N.cm
Panel nut		N.cm
Clamp nut		N.cm
A/F clamp nut	0.000	mm

Mating life	100	Cycles mini
Weight	3.784	g

TOOLING

Part Number	Description	Hexagon
R282.223.000	CRIMPING TOOL	5.41
R282.235.011	CRIMPING DIES	5.41
R282.293.000	CRIMPING TOOL	-

OTHERS CHARACTERISTICS

ENVIRONMENTAL

Operating temperature	-40/+110	° C
Hermetic seal	NA	Atm.cm3/s
Panel leakage	NA	

Issue : 0115 B

In the effort to improve our products, we reserve the right to make changes judged to be necessary.



RADIALL®

R/A COAX PLUG + HOUSING

R197.120.B01

CABLE 5/50

Series : SMB
CARLOCK

RECOMMENDED MOUNTING PROCEDURE

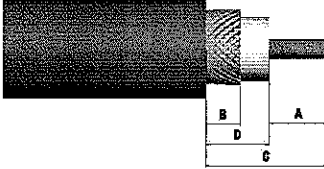
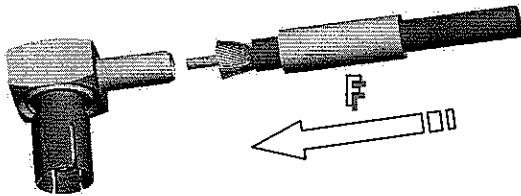
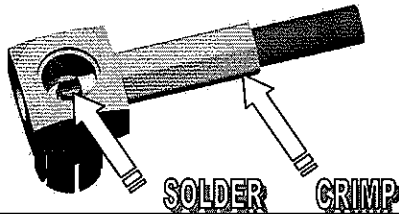
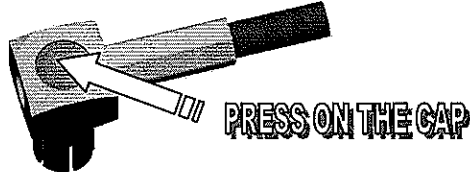
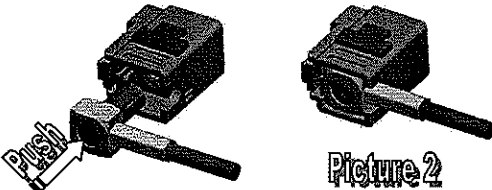
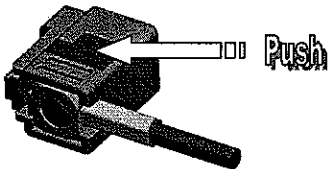
<p>1</p> <ul style="list-style-type: none"> • Slide onto the cable the ferrule • Strip the cable 	
<p>2</p> <ul style="list-style-type: none"> • Fan the braid • Push connector body under the braid • Slide the ferrule on the braid (in direction F) 	
<p>3</p> <ul style="list-style-type: none"> • Crimp the ferrule with crimping tool R282.223.000 (Hex:5.41) or crimping tool R282.293.000 (M22520/5-01) + dies R282.235.011 (M22520/5-11) • Solder inner conductor 	
<p>4</p> <ul style="list-style-type: none"> • Place the cap • Press cap flush or slightly below surface of body assembly 	
<p>5</p> <ul style="list-style-type: none"> • Push the coax in the housing till it snap on (according to picture 2) 	
<p>6</p> <ul style="list-style-type: none"> • To secure the coax inside the housing , push the secondary lock in final position (until it click on) 	

Issue : 0115 B

In the effort to improve our products, we reserve the right to make changes judged to be necessary.



RADIALL®